

B-MOUNT SERIES: B21

Dimensions & Performance Characteristics

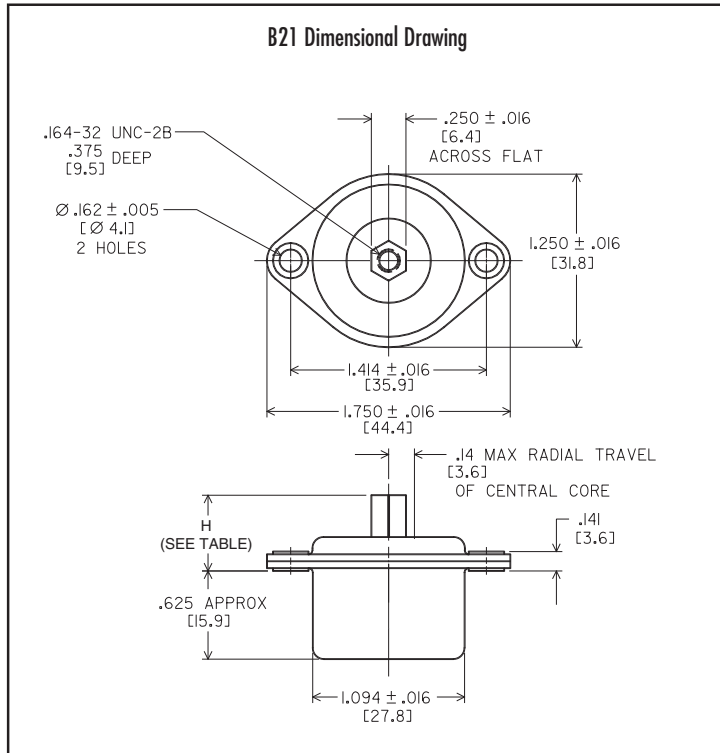

B21 SERIES "H" DIMENSION	
Compressed	.266
Approx. Free	.547
Max. Extended	.813

