

# SLM MOUNT SERIES:

## Dimensions & Load Ranges

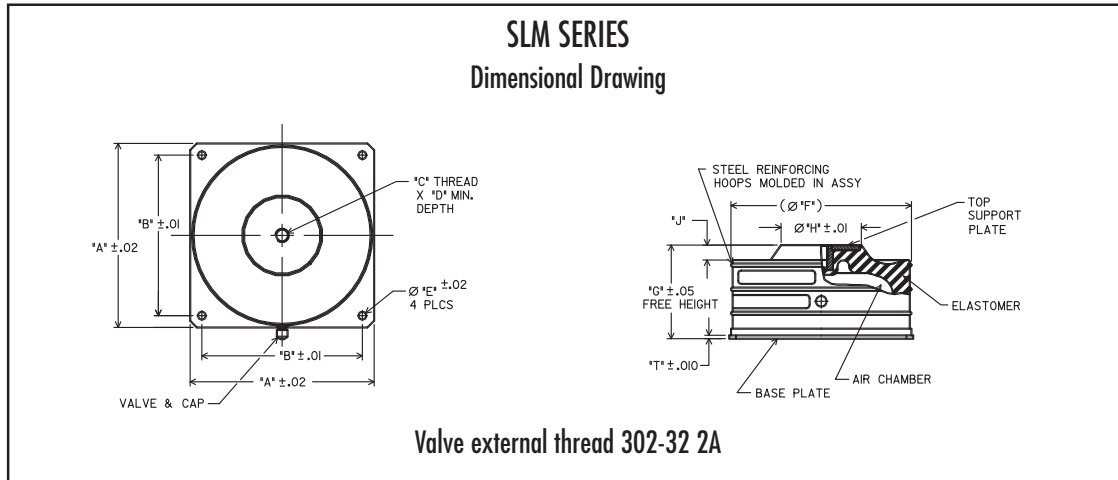

TYPE NO.	MAX. LOAD LBS.	MAX. PRESSURE PSIG	DIMENSIONS										WT. (LBS.)
			"A"	"B"	"C"	"D"	"E"	("F")	"G"	"H"	"J"	"T"	
SLM-1A	100	60	3.00	2.38	.375-16 UNC-2B	.47	.28	2.88	2.50	1.00	.50	.125	1
SLM-3A	300	60	4.19	3.50	.500-13 UNC-2B	.53	.28	4.14	2.45	2.06	.54	.125	1.5
SLM-6A	600	80	5.12	4.25	.500-13 UNC-2B	.53	.29	4.99	3.50	2.38	.56	.125	3.25
SLM-12A	1200	80	6.88	6.00	.500-13 UNC-2B	.53	.29	6.74	3.50	3.75	.56	.125	5.5
SLM-24A	2400	80	10.00	8.50	.625-11 UNC-2B	.75	.56	9.66	3.50	4.75	.56	.188	13
SLM-48A	4800	80	13.50	12.00	.625-11 UNC-2B	.75	.56	13.31	3.50	7.50	.56	.188	26
SLM-96A	9600	80	18.50	16.00	1.000-14 UNS-2B	.88	.81	18.44	3.50	11.60	.56	.250	57
SLM-192A	19200	80	24.00	20.00	1.000-14 UNS-2B	.88	.81	24.00	3.50	15.75	.56	.250	100

METRIC LOAD RANGES & DIMENSIONAL DATA												
PART #	LOAD RANGE (kg)	A	B	C	D	E	(F)	G	H	J	T	Wt. (kg)
SLM-M1A	11-45	76.2	60.4	M10	12.0	7.0	73.2	63.5	25.4	12.7	3.2	0.5
SLM-M3A	34-136	106.4	88.9	M12	14.0	7.0	105.2	62.2	52.3	12.7	3.2	0.7
SLM-M6A	68-272	130.0	108.0	M12	14.0	7.0	126.7	88.9	60.5	14.2	3.2	1.5
SLM-M12A	136-545	174.8	152.4	M12	14.0	7.0	171.2	88.9	95.2	14.2	3.2	2.5
SLM-M24A	272-1090	254.0	215.9	M16	19.0	14.2	245.4	88.9	138.2	14.2	4.8	6
SLM-M48A	545-2180	342.9	304.8	M16	19.0	14.2	338.1	88.9	190.5	14.2	4.8	11.8
SLM-M96A	1090-4360	469.9	406.4	M24	22.0	20.6	468.4	88.9	294.6	14.2	6.4	26
SLM-M192A	2180-8720	609.6	508.0	M24	22.0	20.6	609.6	88.9	400.1	14.2	6.4	45.0